



**Pascal 2010, SD version, 3-phase
motor, 170 – 254 V, 50 Hz | 170 –
300 V, 60 Hz, CE/UL/CSA**



Similar Image

Pascal 2010, SD version, 3-phase motor, 170 – 254 V, 50 Hz | 170 – 300 V, 60 Hz, CE/UL/CSA

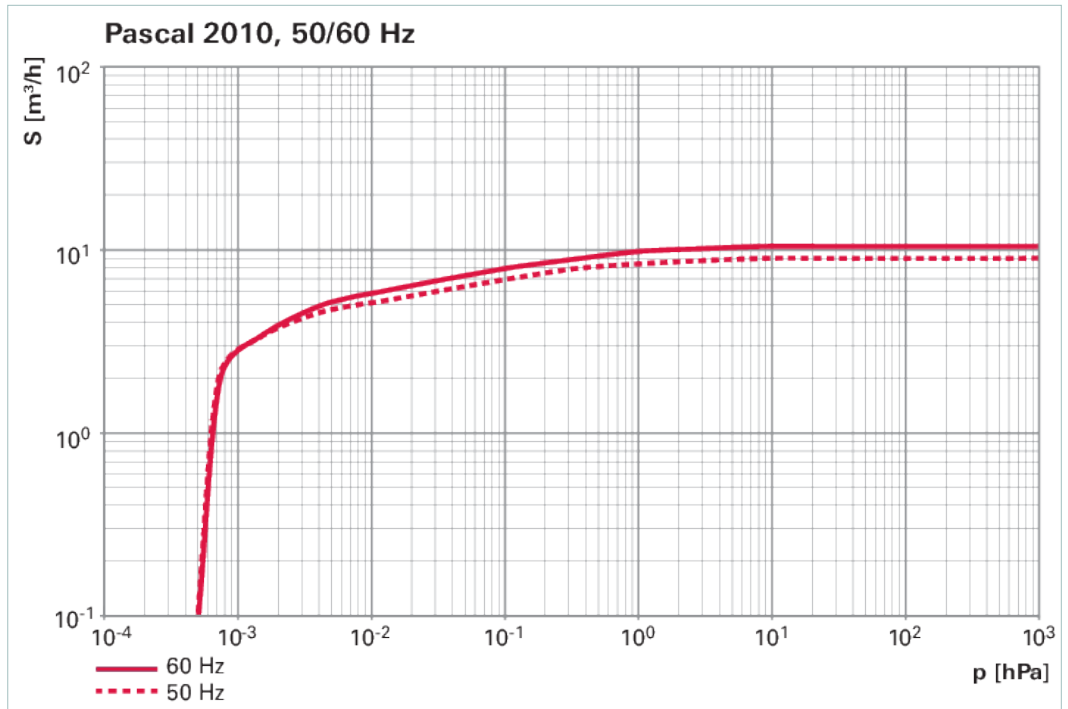
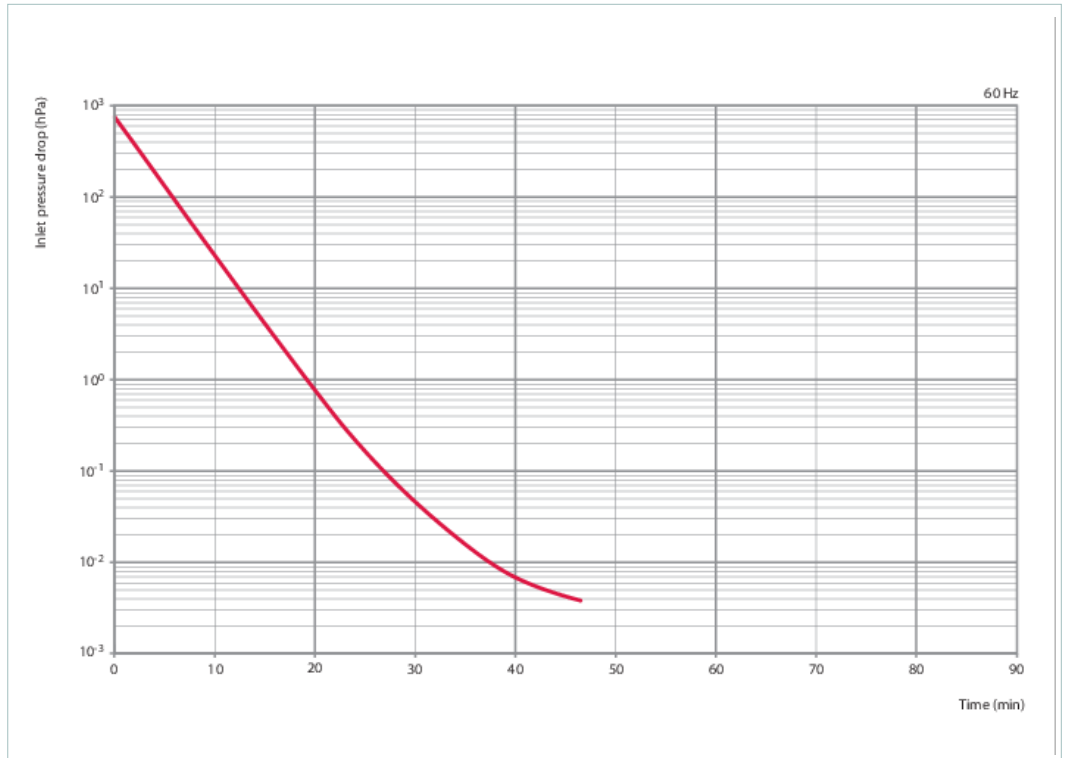

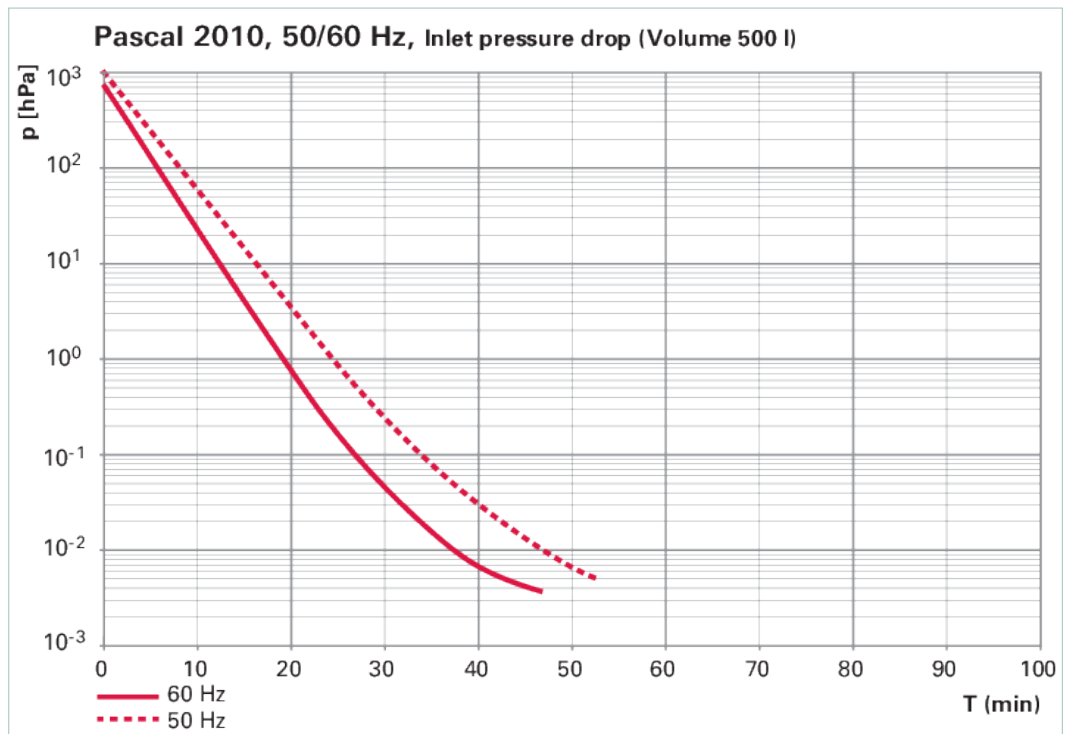

Dimensions

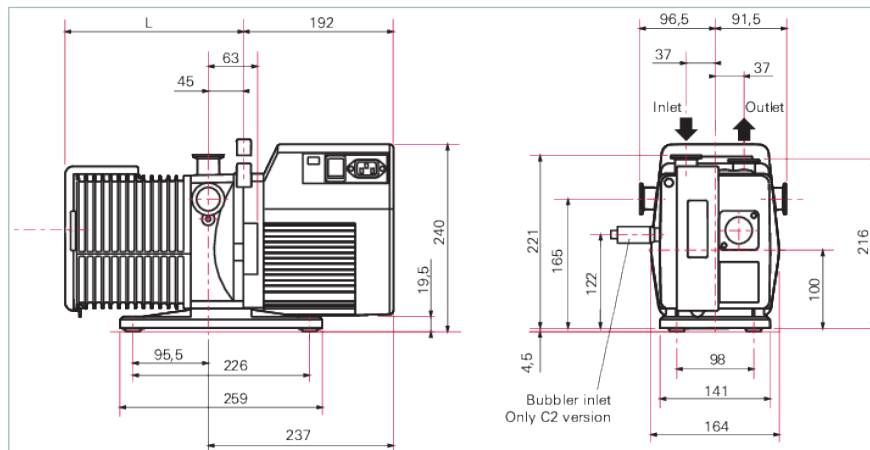

L 245 mm

Technical Data	Pascal 2010, SD version, 3-phase motor, 170 – 254 V, 50 Hz 170 – 300 V, 60 Hz, CE/UL/CSA
Connection flange (in)	DN 25 ISO-KF
Connection flange (out)	DN 25 ISO-KF
Pumping speed at 50 Hz	9 m ³ /h 5.3 cfm 150 l/min
Pumping speed at 60 Hz	10.5 m ³ /h 6.18 cfm 175 l/min
Final pressure	5 · 10 ⁻⁴ hPa 3.75 · 10 ⁻⁴ Torr 5 · 10 ⁻⁴ mbar
Final pressure with gas ballast	1 · 10 ⁻² hPa 7.5 · 10 ⁻³ Torr 1 · 10 ⁻² mbar
Motor for region	Worldwide
Motor type	3-phase motor
Input voltage(s)	170 – 254 V AC, 50 Hz // 170 – 300 V AC, 60 Hz
Mains cable	Yes, US mains cable
Operating fluid	Mineral oil
Rated power 50 Hz	0.55 kW
Rated power 60 Hz	0.66 kW

Technical Data	Pascal 2010, SD version, 3-phase motor, 170 – 254 V, 50 Hz 170 – 300 V, 60 Hz, CE/UL/CSA
Protection degree	IP43
Weight	26 kg 57.32 lb
Order number	
Pascal 2010, SD version	210SDLAM

Accessories	
Connections Connection kits for mounting of pumps	
Connection kit for mounting pumps, DN 25 ISO-KF	120SWS025-1000
ISO-KF, welded bellows sealed	
HV angle valve, DN 25 ISO-KF, manually operated, 304/FKM, "A"-dim. 50 mm	ESV-S03100
Monitoring Oil/Operating fluid level monitoring	
Oil level switch OLS 4	104376
Monitoring Pressure Sensors	
OmniControl 200 with TPR 270	PT 440 950 -T
Protection Catalyzer traps	
URB 025, catalytic trap, 230 V	PT U10 760
URB 025, catalytic trap, 115 V	PT U10 761
Protection Cold traps	
Cold Trap, LN2, angled, DN 25 ISO-KF, 4" body, stainless steel / FPM	FTNA-4-1002-NWB
Protection Condensate separators	
KAS 25 L, condensate separator for pumping speeds up to 35 m ³ /h	PK Z10 033
Protection Dust separators/Inlet particle filters	
SAS 25, dust separator, DN 25 ISO-KF	PK Z60 508
Protection Oil mist eliminators	
Oil mist separator OME 25 S	104200
OME 25 M, oil mist separator for pumping speeds up to 12 m ³ /h	PK Z40 157
Protection Oil return units from oil mist eliminators	
Oil return unit ODK1 from oil mist separator	104360
Oil return unit ODK 2 from OME 25, solenoid valve 230 V 50/60 Hz, Pascal 2005–2021	104361
Oil return unit ODK 2 from OME 25, Pascal 2005–2021, solenoid valve 115 V, 60 Hz	104362
Oil return unit ODK 2 from OME 25, Pascal 2002–2021	104364
Oil return unit ODK 2 from OME 25, Pascal 2005–2021, solenoid valve 24 V DC	104365
Protection Sorption traps	
Sorption trap ST 25 S	104107
Valves Gas ballast valves, magnetic	
Automatic gas ballast AGB 4, 230 V, 50/60 Hz	104086
Automatic gas ballast AGB 4, 115 V	104087
Automatic gas ballast AGB 4, 24 VDC	104089
Automatic gas ballast AGB 4, 200 V, 50/60 Hz	104366
Valves Isolation valves	
AVC 025 PA, angle valve, electro-pneumatic, with PI, with PV, PV 24 V DC	PF A48 204
Consumables	
A120, hydrocarbon oil, 2 L	068099
A111, mineral oil, 2 L	064655
A102, hydrocarbon oil, 2 L	010996
A119, hydrocarbon oil, 1 L	103855
A121, hydrocarbon oil, 1 L	102724

VACUUM SOLUTIONS FROM A SINGLE SOURCE

Pfeiffer Vacuum stands for innovative and custom vacuum solutions worldwide, technological perfection, competent advice and reliable service.

COMPLETE RANGE OF PRODUCTS

From a single component to complex systems:

We are the only supplier of vacuum technology that provides a complete product portfolio.

COMPETENCE IN THEORY AND PRACTICE

Benefit from our know-how and our portfolio of training opportunities!

We support you with your plant layout and provide first-class on-site service worldwide.

Are you looking for a
perfect vacuum solution?
Please contact us:

Pfeiffer Vacuum GmbH
Headquarters · Germany
T +49 6441 802-0
info@pfeiffer-vacuum.de

www.pfeiffer-vacuum.com

All data subject to change without prior notice.

PFEIFFER  **VACUUM**